

MANUAL

**Digital Multi Control Panel
(DMC)**

VICTRON ENERGY AT ANY TIME



victron energy

This publication or parts thereof, may not be reproduced in any form, by any method, for any purpose.

For conditions of use and permission to use this manual for publication in other than the English language, contact Victron Energy B.V.

VICTRON ENERGY B.V. MAKES NO WARRANTY, EITHER EXPRESSED OR IMPLIED, INCLUDING BUT NOT LIMITED TO ANY IMPLIED WARRANTIES OF MERCHANTABILITY OR FITNESS FOR A PARTICULAR PURPOSE, REGARDING THESE VICTRON ENERGY PRODUCTS AND MAKES SUCH VICTRON ENERGY PRODUCTS AVAILABLE SOLELY ON AN "AS IS" BASIS.

IN NO EVENT SHALL VICTRON ENERGY B.V. BE LIABLE TO ANYONE FOR SPECIAL, COLLATERAL, INCIDENTAL, OR CONSEQUENTIAL DAMAGES IN CONNECTION WITH OR ARISING OUT OF PURCHASE OR USE OF THESE VICTRON ENERGY PRODUCTS. THE SOLE AND EXCLUSIVE LIABILITY TO VICTRON ENERGY B.V., REGARDLESS OF THE FORM OF ACTION, SHALL NOT EXCEED THE PURCHASE PRICE OF THE VICTRON ENERGY PRODUCTS DESCRIBED HERE IN.

Victron Energy B.V. reserves the right to revise and improve its products as it sees fit. This publication describes the state of this product at the time of its publication and may not reflect the product at all times in the future.

Contents

- 1 Quick Start
- 2 Standard installations
 - 2.1 VE.Bus system with 1 AC source
 - 2.2 VE.Bus system with 2 AC sources
 - 2.2.1 Extended VE.Bus system with Multis
 - 2.2.2 VE.Bus system build with Quattro's
 - 2.2.3 VE.Bus Multi system + external transfer switch (PowerMan)
 - 2.3 Non VE.Bus system with 1 AC source
 - 2.4 Non VE.Bus system with 2 AC sources
- 3 Description of the Digital Multi Control panel
 - 3.1 Generator support
 - 3.2 Connecting VE.Bus devices
 - 3.3 Connecting non-VE.Bus devices
- 4 Installation of the Digital Multi Control panel
 - 4.1 Bus cable
 - 4.2 Transfer switch wiring
- 5 Using the Digital Multi Control panel
 - 5.1 Turning the system on and off
 - 5.2 Setting the system input current limit
 - 5.3 LED brightness
- 6 Configuring the Digital Multi Control panel
 - 6.1 Procedure
 - 6.2 Setting the scaling factor
 - 6.3 Setting the generator current limit
 - 6.4 Setting the Upper Shore limits for AC input 1 to 4
 - 6.4.1 Special display feature
 - 6.5 Configuration examples
- Appendix 1 Technical data



1 Quick Start

The Digital Multi Control panel (DMC) is a remote panel designed to work with all Multis/Quattro's and Multi/Quattro systems. This includes stand alone, parallel and 2-3 phase configurations. Both VE.Bus and non VE.Bus systems are supported.

Connecting the DMC to your system is a simple procedure. In most cases just connecting the DMC with a RJ45 cable is sufficient and no extra set-up handling is required.

To help you to set-up your system rapidly this manual contains in chapter 2 several paragraphs for the most common applications. Please find your application in the table below and jump to the appropriate paragraph.

For a more generic description of this panel please refer to chapter 3.

To setup a:	Refer to paragraph
VE.Bus system with 1 AC source	2.1
VE.Bus system with 2 AC sources	2.2
Extended VE.Bus system with Multis	2.2.1
VE.Bus system build with Quattro's	2.2.2
VE.Bus Multi system + external transfer switch (PowerMan)	2.2.3
Non VE.Bus system with 1 AC source	2.3
Non VE.Bus system with 2 AC sources	2.4

Notes:

- 1) The word "system" refers to an installation of one or more Multis or Quattro's.
- 2) To determine whether or not your system is VE.Bus, check the firmware version in the Multi. All Multi firmware versions 15xyyy, 17xyyy and 18xyyy are **non** VE.Bus. (Quattro's are always VE.Bus.)

2 Standard installations

2.1 VE.Bus system with 1 AC source

Setup for such a system is easy: Just connect the DMC to the VE.Bus system (see paragraph 4.1) and the DMC will automatically adapt to the current system.

No parameters need to be changed in the DMC unless you want to limit the maximum current the operator can set. In that case you only need to adapt the "Upper shore limit for AC input 1" setting. Refer to chapter 6 for a description of how to do this.

2.2 VE.Bus system with 2 AC sources

There are several ways to build a VE.Bus system with 2 AC sources. Refer to the appropriate sub-paragraph for your installation.

2.2.1 Extended VE.Bus system with Multis

A system with more than 1 AC input can be build with normal Multis. The extended VE.Bus functionality is used for this purpose. This functionality comes available when a dongle is connected to the system. The system must then be configured with the "VE.Bus System Configurator" tool.

From the DMC point of view there is no difference between a system build with Quattro's and a system build with Multis. So read on with paragraph 2.2.2. Note that, by using VeConfigure2, it is possible to determine whether or not an AC input shore limit can be overruled by the remote panel.

2.2.2 VE.Bus system built with Quattro's

If your system is build with one or more Quattro's the installation of the DMC is straight-forward. Just connect the DMC to the VE.Bus system (see paragraph 4.1) and the DMC will automatically adapt to the current system.

Most likely you do not need to change any settings in the DMC.

In a Quattro the AC1 input has always priority over the AC2 input. The default setting in a Quattro is that the AC2 shore current can be overruled by the remote panel and the AC1 limit is fixed. (This can be changed with VeConfigure2)

A common practice is that a generator is connected to AC1 and shore power to AC2. As long as the generator is running the Quattro's will use the generator. The DMC will display $R_c 1$ in that case and turning the knob on the DMC will not have any influence. When the generator is stopped and shore power is applied, the Quattro's will switch to the shore power. Now the DMC will continuously toggle the display between $R_c 2$ and the current shore limit set point. Turning the knob will now change the shore limit set point in the Quattro's.

If you want to limit the maximum current the operator can set you can change the "Upper shore limit for AC input 2" parameter. Refer to paragraph 6 for a description of how to do this.

Please refer to paragraph 6.4.1 if you want to get rid off the display toggling ($R_c 2 \leftrightarrow$ shore limit value).

2.2.3 VE.Bus Multi system + external transfer switch (PowerMan)

If an external transfer switch is placed before the Multis then this switch determines which AC source is used. The Multis do not have any information about the state of the switch. The DMC provides a way to specify different shore limits for both AC sources.

To achieve this, the DMC must have information about the state of the external transfer switch. For this purpose a screw connector is placed at the backside of the DMC.

Normally the DMC will send the shore current set point as determined by the knob to the Multis. If however the terminals of this screw connector are short circuited the DMC sends a preconfigured shore limit to the Multis. The display on the DMC will then show: $\overline{L} \overline{E} \overline{N}$.

The two terminals of the screw connector are to be connected to the PowerMan. An auxiliary relay of the external transfer switch is the normal place. Refer to the transfer switch manual for more information.

Refer to chapter 4 for a description on how to connect the DMC to the system.

For this application, the DMC has to be configured because it must “know” the current limit it should send to the Multis when the terminals are short circuited. Please change the “Generator current limit” parameter as needed. Refer to chapter 6 for a description of how to do this.

If you want to limit the maximum current the operator can set, you can change the “Upper shore limit for AC input 1” parameter. Refer to chapter 6 for a description of how to do this.

2.3 Non VE.Bus system with 1 AC source

The DMC must be scaled (matched to the system) when it is used with non VE.Bus systems. This can be done by changing the “scaling factor” parameter. Refer to the configuration chapter for a description of how to do this.

After correct scaling the maximum current limit the operator can set is equal to the maximum limit of the system. If you want to limit the maximum current the operator can set, you have to adapt the “Upper shore limit for AC input 1” setting. Refer to the configuration chapter for a description of how to do this.

2.4 Non VE.Bus system with 2 AC sources

The DMC must be scaled (matched to the system) when it is used with non VE.Bus systems. This can be done by changing the “scaling factor” parameter. Refer to chapter 6 for a description of how to do this.

A non VE.Bus system with 2 AC sources can only be build with an external transfer switch (PowerMan). Installation is exactly the same as when using a VE.Bus system with an external transfer switch so please refer to paragraph 2.2.3.

3 Description of the Digital Multi Control panel

The DMC is a remote panel designed to work with all Multis/Quattro's and Multi/Quattro systems. This includes stand alone, parallel and 2-3 phase configurations. Both VE.Bus and non VE.Bus systems are supported.

With the DMC a separate shore current and generator current can be set.

When used in an extended VE.Bus system one can even set up to 4 different shore currents. For VE.Bus systems, the DMC will automatically adapt the adjustable range to match with the connected system.

3.1 Generator support

The DMC provides a means to change the AC input current limit when the AC source is switched externally from shore to generator.

Normally the DMC will send the shore current set point as determined by the knob to the connected devices. If however the terminals of the screw connector on the backside of the DMC are short circuited the DMC sends a preconfigured shore limit to the connected devices.

This preconfigured limit is generally used for a generator. The display on the DMC will therefore show: $\bar{C} \bar{E} \bar{I}$.

The two terminals of the screw connector are to be connected to an externally controlled switch. Normally spoken this will be an auxiliary relay of an external transfer switch.

3.2 Connecting VE.Bus devices

Using the DMC with VE.Bus devices is straightforward. Just connect the DMC to the system. The maximum/minimum shore currents which can be set are automatically adapted to the system.

This means that:

- Connecting the DMC to one Multi with 16A feed through capacity will limit the maximum shore setting to 16A.
- Connecting the DMC to five of these Multis in parallel will result in 80A as maximum shore limit. (If needed, an upper limit can be set to prevent the operator from setting a too high shore limit. See section 6.4)

The DMC is capable of dealing with a Quattro or an extended VE.Bus system which has more than 1 AC input. When the system switches over from one AC input to another, the DMC switches too, setting the current limit to the last used value for that AC input.

In the Multi/Quattro configuration it is possible to indicate that a shore current limit is not to be overruled by the remote panel. In such a case the DMC will not display a shore current limit value but it will display the AC input identification as $R_c 1$, $R_c 2$, $R_c 3$ or $R_c 4$.

If, in a system with more than 1 input, the corresponding input does allow changing by the remote panel, the DMC will display the shore current value and the AC input identification alternating. Exception to this is AC input 1. If AC input 1 is active only the shore current value will be displayed and not the AC input identification.

3.3 Connecting non-VE.Bus devices

In order to operate the DMC with non VE.Bus devices one must configure a scaling parameter to match the DMC with the connected system.

The default setting is for a standalone Multi with a 16A transfer switch.

There will be no adjustment for the minimum shore current limit in this case.

(If needed, an upper limit can be set to prevent the operator from setting a too high limit. See section 6.4)

4 Installation of the Digital Multi Control panel

To install your DMC you will need:

- 1) One UTP (Unshielded Twisted Pair) cable with two RJ45 connectors (to connect to a Multi or Quattro) available in 5, 10, 15, 20, 25 and 30 meters.
- 2) When the Generator support functionality (see paragraph 3.1) of the DMC is used you will also need two wires for connecting the DMC to the transfer switch. This connection can be made by using 2 wires of 0.25 – 1.0mm². Refer to the transfer switch manual for more information.

4.1 Bus cable

To connect the DMC to a Multi or Quattro use a standard straight UTP cable with RJ45 connectors.

Note: In case of a non VE.Bus parallel system connect the DMC to the master Multi.

4.2 Transfer switch wiring

Only when an external transfer switch is used one has to connect a switch to the screw connector on the back of the DMC. When the switch is open the current limit is controlled by the knob on the front of the DMC. When the switch is closed the DMC sends the preset generator current limit to the connected devices. This switch is normally controlled by your shore/generator transfer switch.

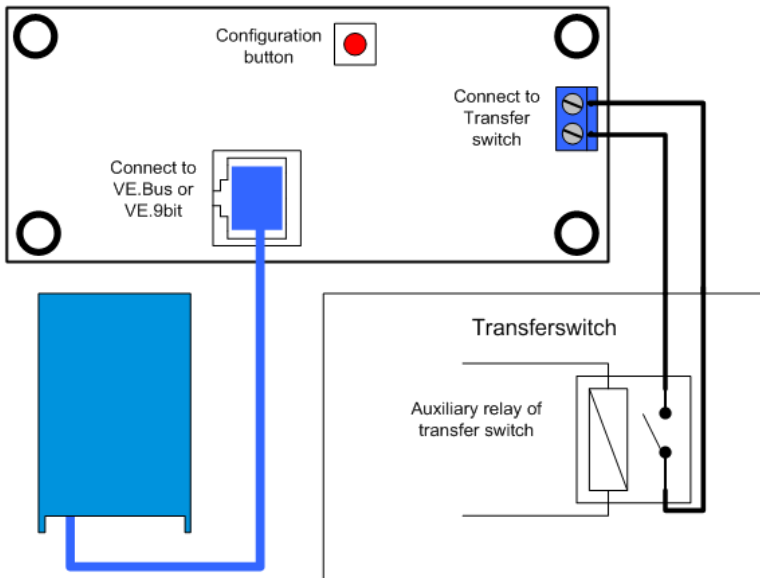

5 Using the Digital Multi Control panel

The DMC is used to remotely set up to four (five including the generator functionality) different input currents, read out the status of your system and turn on and off the Multis or Quattro's.



5.1 Turning the system on and off

Use the switch on the front to turn the system on, off or to charger only operation.

5.2 Setting the system input current limit

The shore current limit is set by the control knob on the DMC. Turn the knob right or left to set the desired value. The current limit will be shown on the 7-segment display.

The generator current limit can be set during installation. See chapter 6 for detailed instructions.

When PowerAssist is enabled there is a minimum AC input current limit of approximately 2-3Amp per device. Setting a lower limit than this minimum will result in the minimum limit. This is normal Multi/Quattro behaviour.

There is a feature in the Multi/Quattro that, when PowerAssist is enabled and the shore current setting from the remote panel is zero amps, the internal transfer relay is opened and the device starts inverting.

VE.Bus only:

- The DMC will not allow you to set a limit lower than the minimum shore current limit. To be able to use the above mentioned feature, the DMC allows the operator to set the shore current limit to 0 Amps which is actually below the minimum shore current limit. To achieve this, the operator must turn the knob 'downwards' with a higher speed. The display will then 'jump' to 0.0 and the connected device(s) will start inverting. When the knob is turned upwards again the display will 'jump' to the minimum shore current limit.
- If your system has more than 1 AC input the display will also indicate which input is currently in use by displaying *AC 1*, *AC 2*, *AC 3* or *AC 4*.

5.3 LED brightness

For your comfort, the brightness of the LEDs is controlled automatically using a light sensor. When the ambient light level becomes lower the LEDs will be less bright which is more pleasant for the eye and reduces power consumption.

6 Configuring the Digital Multi Control panel

This chapter describes the configuration parameters and procedure.

6.1 Procedure

During configuration 6 parameters can be set. The configuration procedure is straight forward.

- To enter the configuration mode press the button on the back of the DMC until the bottom LED in the left column starts flashing, indicating that the first parameter can be changed.
- To change the value of a parameter, turn the knob until the displayed value is as required.
- Press the button to advance to the next parameter.

The lower three LEDs in the left column on the DMC indicate which parameter is being adjusted according to the table below:

LED indication	Selected parameter
<p>○</p> <p>○</p> <p>✱</p>	<p>Scaling factor. default:0, range:0-9 (this parameter is ignored when using VE.Bus devices)</p>
<p>○</p> <p>○</p> <p>✱</p>	<p>Generator current limit in Amps. default:16, range:0..198</p>
<p>○</p> <p>✱</p> <p>✱</p>	<p>Upper shore limit for AC input 1 in Amps. default:254, range:0..254</p>
<p>○</p> <p>✱</p> <p>✱</p>	<p>Upper shore limit for AC input 2 in Amps. default:254, range:0..254</p>
<p>✱</p> <p>✱</p> <p>✱</p>	<p>Upper shore limit for AC input 3 in Amps. default:254, range:0..254</p>
<p>✱</p> <p>✱</p> <p>✱</p>	<p>Upper shore limit for AC input 4 in Amps. default:254, range:0..254</p>

○ means LED is off, ✱ means LED is blinking, ✱ means LED is on

Notes:

- The connected Multis or Quattro's switch to "Inverter only" when the configuration button is pressed and during configuration mode.
- Pressing the button when the last parameter of the table is selected will end configuration mode and activate all parameters. So even if only one parameter needs to be adjusted you have step through all parameters to exit the configuration mode.

6.2 Setting the scaling factor

Configuration of the scaling factor is only needed for non VE.Bus Multis. (All Multi firmware versions 15xyyy, 17xyyy and 18xyyy)

The scaling factor is used to match the currents displayed by the DMC to the currents in the system.

The scaling factor is calculated using the formula:
Scaling factor = (NrOfDevices * DeviceType) - 1

The DeviceType is 1 for a 16A model Multi and 2 for a 30A model Multi.
NrOfDevices is all the Multis **including** the master Multi.

Example: You have four 30A Multis. The scaling factor is then: $(4 * 2) - 1 = 7$

Important notes:

- 1 *Do NOT specify the number of slaves (with VEConfigure2) in the Multis when you have specified a Scaling factor other than zero!
In that case the number of slaves in the Multis must be set to zero!
The system will not work properly if you set the scaling factor in the DMC and the number of slaves in the Multis!*
- 2 *When using a split-phase or 3-phase configuration, the NrOfDevices is determined by the number of devices in 1 phase. So for a 3-phase system build with 6 Multis the NrOfDevices=2.*

6.3 Setting the generator current limit

This parameter needs only to be configured when using an external transfer switch (PowerMan) (see paragraph 3.1) and is of no influence otherwise.
The generator current limit can be set from 0 to 198 Amps in steps of 2 Amps.

Important note:

Small 3000 rpm generator sets of certain brands will overheat when operating for long periods at full load. In some cases the maximum current will have to be set at no more than 70 % of the rated maximum current. The current limit of 1500 rpm generator sets can in general be set at around 90 % of the rated output current.

6.4 Setting the Upper Shore limits for AC input 1 to 4

To prevent that the operator of the DMC sets a too high current limit for the system an Upper Shore limit can be set.

Example: You have a system with 5 Multis in parallel. The maximum feed through current would be 80A. This might be a far too high setting for the circuit breakers used in your system. By adjusting the "Upper Shore limit" you can prevent that the shore current limit is set higher than, for instance, 30A.

Four different limits can be set because VE.Bus systems can have up to 4 AC inputs. For simple VE.Bus systems with Multis or non VE.Bus systems it is sufficient to set only the "Upper Shore limit for AC input 1". The others will not be used then.

6.4.1 Special display feature

When you have an extended VE.Bus system (or a Quattro system) and you use more than 1 AC input you might come across the following situation:

Assume you use 2 AC inputs. You would like to give the generator priority over the shore so you connect the generator to AC input 1. However you do not want the panel operator to adapt the current limit set point of the generator so with VEConfigure2 you uncheck the 'overruled by remote' checkbox for the current limit setting for AC input 1.

You connect the shore current to AC input 2. For AC Input 2 you leave the 'overruled by remote' checkbox checked.

The DMC will then behave as follows:

If the generator is selected the DMC displays $R_c 1$.

When the generator is switched off and shore current is applied, the DMC will display the set point for AC input 2 alternating with the AC input identification $R_c 2$.

This might not be what you want or expect because why should the display alternate between the value and $R_c 2$? There is only one set point which the user can change! When the other AC input is selected the display will always display $R_c 1$. It would be sufficient to display the current limit value when AC input 2 is selected because that is enough indication for the operator that the system is switched to shore current.

To achieve this, all but one of the "Upper Shore limits" must be programmed to zero.

So in this example the limits for AC1, AC3 and AC4 must be programmed to zero. The display will then not alternate between $R_c 2$ and the set point for AC2.

Summary: Setting all but one of the "Upper Shore limits" to zero will stop the display toggling for the "remaining" AC input.

6.5 Configuration examples

Two examples are given to help you understand the setting of the parameters.

Example 1: Two VE.Bus Multis 16A/230V + 4kVA gen. (3000 rpm) + external transfer switch.

Because this is a VE.Bus system the scaling factor does not need to be set.

A 4kVA generator can supply a maximum current of 17,4A. Using the 70% safety margin we will set the generator current to 12A. To set the configuration, do the following:

- 1) Press and hold the configuration button until the bottom LED in the left column starts flashing. This means you entered the configuration mode and you can change the scaling factor. As said this parameter can be ignored in case of VE.Bus Multis.
- 2) Press the button to go to the next setting. The lower left LED will turn on indicating that the generator current can be set.
- 3) Turn on the knob until the display indicates 12.
- 4) Press the button to advance to the "Upper Shore limit for AC input 1" setting.
- 5) If you want the maximum shore current the operator can set to be lower than 32 Amps you can change this value.
- 6) Since the next 3 parameters (Upper Shore limit for AC input 2, 3 and 4) need not to be configured you can press the button 4 times to step through the settings and finalize the configuration.

Example 2: Four non VE.Bus Multis 30A/120V + 13kVA gen. (1500 rpm) + external transfer switch.

For this configuration the "scaling factor" must be calculated. The NrOfDevices is 4, the DeviceType is 2 so the "scaling factor" is $(4 \times 2) - 1 = 7$

A 13kVA generator 120V can supply a maximum current of 108,3A. Using the 90% safety margin we will set the generator current to 98A. To set the configuration, do the following:

- 1) Press and hold the configuration button until the bottom LED in the left column starts flashing. This means you entered the configuration mode and you can change the scaling factor.
- 2) Turn on the knob until the display indicates 7.
- 3) Press the button to go to the next setting. The lower left LED will turn on indicating that the generator current can be set.
- 4) Turn on the knob until the display indicates 98.
- 5) Press the button to advance to the "Upper Shore limit for AC input 1" setting

- 6) You probably want the maximum shore current the operator can set to be lower than 128 Amps so turn the knob until the display indicates a proper maximum shore current.
- 7) Since the next 3 parameters (Upper Shore limit for AC input 2, 3 and 4) need not to be configured you can press the button 4 times to step through the settings and finalize the configuration.

Appendix 1 Technical data

Supply voltage range	9 ... 70VDC
Supply current	Standby Active
@12V	<5mA <30mA
@24V	<5mA <15mA
Operating temperature range	0 ... 50°C
Dimensions	65 x 120 x 55mm
Net weight	120 gram
Material:	
Body	Aluminum



Victron Energy B.V.

De Paal 35

1351 JG Almere

PO Box 50016

1305 AA Almere

The Netherlands

www.victronenergy.com

Version: 3.1

Date: October 2008