

W A T E R M A K E R S

M A R I N E B R O C H U R E



Horizon
Reverse
Osmosis™

Pioneer of fresh water since 1975



Spend more time on the water, and less time on your watermaker.

For over 30 years, Horizon Reverse Osmosis has built a reputation of manufacturing the most reliable and intuitive systems in the world. Our systems are not only engineered to create fresh water, but are also engineered to be more convenient, to last longer, and to give you more peace of mind. You can trust the manufacturer with the most experience and certifications in the industry. With support from Horizon Reverse Osmosis and our global network of dealers, your supply of fresh water will never run out.

Contents	Page
Self Contained & Modular	4 - 5
Mini	6 - 7
Escape	8 - 9
Coral Sea	10 - 11
Accessories	12
System Specifications	13
Dimensions & Specifications	14 - 15



Picture courtesy of Riviera Electronics





All the
conveniences
of home on
your boat.



Seafari *Self Contained*™

Along the coast or around the world...

With systems capable of producing up to 1800 gallons per day, you'll find that the Seafari is perfect for weekend fishing, or blue water cruising. Engineered to be hassle-free, the Seafari is Horizon Reverse Osmosis's most versatile and easily operable system. The Seafari is also capable of withstanding the ocean's harshest conditions, while maintaining its high level of quality. Simple and reliable, the Seafari is the watermaker for every boater.

Model Number	Per 24 Hours	Per Hour	Weight
Seafari SFC/SFM 450-1	450 Gal / 1,700 Lit	18 Gal / 70 Lit	118 lbs / 54 kg
Seafari SFC/SFM 700-1	700 Gal / 2,650 Lit	26 Gal / 110 Lit	125 lbs / 57 kg
Seafari SFC/SFM 900-1	900 Gal / 3,405 Lit	38 Gal / 140 Lit	136 lbs / 62 kg
Seafari SFC/SFM 900-2	900 Gal / 3,405 Lit	38 Gal / 140 Lit	136 lbs / 62 kg
Seafari SFC/SFM 1400-2	1,400 Gal / 5,300 Lit	58 Gal / 220 Lit	147 lbs / 67 kg
Seafari SFC/SFM 1800-2	1,800 Gal / 6,815 Lit	75 Gal / 285 Lit	150 lbs / 68 kg

Refer to page 14 for system dimensions and additional specifications.



Seafari Modular™

Any boat. Any destination.



Picture courtesy of Riviera Electronics



Seafari **Mini**™

Don't let its small size fool you.

Ranging from 170 to 350 gallons of water per day, the Seafari Mini is the perfect solution for boats with little space to spare. Offering the largest production capacity for its size, you can be sure to have plenty of fresh water, without wasting precious storage or engine room space.

Model Number	Per 24 Hours	Per Hour	Weight
Seafari Mini 170	170 Gal / 645 Lit	7 Gal / 25 Lit	95 lbs / 43 kg
Seafari Mini 350	350 Gal / 1,325 Lit	15 Gal / 55 Lit	125 lbs / 57 kg

Refer to page 14 for system dimensions and additional specifications.



How to store 350 gallons in
2.5 square feet of space.



Picture courtesy of Hunter Marine



Mini 350

Seafari *Escape*™

Powerfully Efficient.

Featuring Horizon Reverse Osmosis's EfficientSea technology, the Seafari Escape is capable of reducing its total power consumption by up to 75%. With the installation of its patented Energy Transfer Device, the need for a high-pressure pump is eliminated. The result is a system that is efficient, virtually noiseless, and capable of running on either AC, or DC power. Producing between 200 to 600 GPD, the Seafari Escape is perfectly suited for smaller to mid-sized yachts.

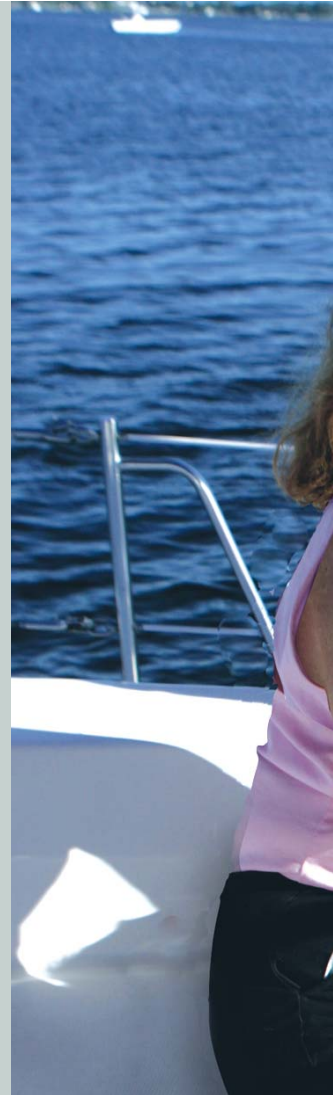

Model Number	Per 24 Hours	Per Hour	Compact Weight	Modular Weight
Escape 200	200 Gal / 760 Lit	8 Gal / 30 Lit	105 lbs / 48 kg	105 lbs / 48 kg
Escape 300	300 Gal / 1,135 Lit	13 Gal / 45 Lit	115 lbs / 52 kg	115 lbs / 52 kg
Escape 400	400 Gal / 1,515 Lit	17 Gal / 65 Lit	120 lbs / 54 kg	120 lbs / 54 kg
Escape 500	500 Gal / 1,890 Lit	21 Gal / 80 Lit	120 lbs / 54 kg	120 lbs / 54 kg
Escape 600	600 Gal / 2,270 Lit	25 Gal / 95 Lit	120 lbs / 54 kg	120 lbs / 54 kg

Refer to page 15 for system dimensions and additional specifications.



Save energy for more important things.



Picture courtesy of Hunter Marine



Coral Sea™

Engineered for everything from megayachts to small hotels, the Coral Sea is a marine and commercial crossover.

Featuring semi-automatic operation with a state-of-the-art controller, the Coral Sea system offers a user-friendly LCD touch screen interface, displaying pictorial images of all operating conditions, which can also be viewed with the optional full remote matching touch screen from any location on the boat.

The Coral Sea desalinator is the ultimate solution for mega yachts, commercial fishing vessels, workboats, oil rigs, charter boats, and land-based ocean front villas, restaurants, laundry facilities, and private residences.

Model Number	Per 24 Hours	Per Hour
Coral Sea with 3" R.O. Membrane Elements: Horizontal, Vertical, Modular		
3" 2800 GPD	2,800 Gal / 10,600 Lit	115 Gal / 440 Lit
3" 3600 GPD	3,600 Gal / 13,625 Lit	150 Gal / 570 Lit
Coral Sea with 4" R.O. Membrane Elements: Horizontal, Vertical		
4" 4200 GPD	4,200 Gal / 15,900 Lit	175 Gal / 660 Lit
4" 5200 GPD	5,200 Gal / 19,685 Lit	215 Gal / 820 Lit
4" 6200 GPD	6,200 Gal / 23,470 Lit	260 Gal / 980 Lit
4" 6800 GPD	6,800 Gal / 25,740 Lit	285 Gal / 1,075 Lit



Coral Sea Horizontal



Fresh water
from the
ocean to
the shore.



Electrical Specifications:

At normal operation the booster pump starts first, then several seconds later the high-pressure pump starts. (H.P. = Horse Power; RPM = Revolutions Per Minute; FLA = Full Load Amperes; LRA = Locked Rotor Amperes @ Start Up; Max. = Maximum). Specify AC voltage, cycles and phase when ordering.

Coral Sea 2800 & 3600 single phase AC dual voltage electric motors:

Pump Motor	Voltage VAC	Hz	H.P.	RPM	Max. FLA	Max. LRA
Booster Pump	220/230	50/60	1	2850/3450	5.7 / 5.5	40/38.5
High-Pressure Pump	220/230	50/60	5	1438/1725	26.3 / 21	183/146

Coral Sea 4200 - 6800 single phase 230V:

Pump Motor	Voltage VAC	Hz	H.P.	RPM	Max. FLA	Max. LRA
Booster Pump	220/230	50/60	1	2850/3450	5.7 / 5.5	40/38.5
High-Pressure Pump	220/230	50/60	10	1438/1725	39 / 40	200/210

All Coral Sea systems operating from three phase AC:

Pump Motor	Voltage VAC	Hz	H.P.	RPM	Max. FLA	Max. LRA
------------	-------------	----	------	-----	----------	----------

Coral Sea 2800 & 3600

Booster Pump	220/380	50	1	2850	3.3/1.9	26/15
High-Pressure Pump	220/380	50	5	1438	21/9.6	138/80
Booster Pump	208/230/460	60	1	3450	3.5/3.2 /1.6	27.6/25/12.5
High-Pressure Pump	208/230/460	60	5	1725	14.6/13.2/6.6	122/110/55

Coral Sea 4200, 5200, 6200, & 6800

Booster Pump	220/380	50	1	2850	3.3/1.9	26/15
High-Pressure Pump	220/380	50	10	1438	33/19	276/160
Booster Pump	208/230/460	60	1	3450	3.5/3.2/1.6	27.6/25/12.5
High-Pressure Pump	208/230/460	60	10	1725	29/26/13	243/220/110

Recommended amperage rating of circuit breaker:

System Model	AC Voltage	Cycles	Phase	Circuit Breaker Amp
Coral Sea 2800 & 3600	220/230	50/60	single	65/55
Coral Sea 2800 & 3600	220/380	50	three	50/25
Coral Sea 2800 & 3600	208/230/460	60	three	35/35/15
Coral Sea 4200 - 6800	220/380	50	three	70/40
Coral Sea 4200 - 6800	208/230/460	60	three	65/60/30

Coral Sea weights:

	2800	3600	4200	5200	6200	6800
Horizontal in lbs. / Kg	473/215	485/220	750/340	800/364	850/386	900/409
Vertical in lbs. / Kg	473/215	485/220	700/318	750/340		
Modular in lbs. / Kg	425/193	435/197				

External installation water connections:

Coral Sea 2800 & 3600 all ANSI Threaded Flange:

Feed Inlet 3/4", Clean Inlet 3/4", Brine Discharge 3/4", Clean Return 3/4", Product 1/2"

Coral Sea 4200, 5200, 6200, & 6800 all ANSI Threaded Flange:

Feed Inlet 1", Clean Inlet 1", Brine Discharge 1", Clean Return 1", Product 3/4"

Refer to page 15 for system dimensions and additional specifications.



Coral Sea Vertical

Coral Sea Modular

Optional Accessories

Find out which accessories are right for you.

Outfitting your system with the necessary options and accessories will add more life to your watermaker, and eliminate maintenance costs.



Oil/Water Separator
The newly redesigned assembly removes oil from the feed water. Perfect for marinas or harbors! (No charge option.)



Commercial Pre-filter
This new, more compact pre-filter, saves maintenance time and costs. (No charge option.)



Media Filter
Removes sand and other various media from the feed water. This extends the life of the pre-filter.



UV Sterilizer
Eliminates 99.8% of bacteria, viruses, and microorganisms from the feed water.



Mesh Sea Strainers
Traps sand with mesh screen, extending pre-filter life.



Soft Start Motor
Reduces the start up of a watermaker by 55%. It is only available for single phase, 110/ 220VAC, 50/60 Hz systems.



Clean Rinse Panel
Separate mounted valves allow for easy R.O.membrane maintenance and complete system rinsing.



Remote Control
Be able to control and monitor the watermaker from anywhere on the yacht.



Meter DS Pocket
Measures the amount of total dissolved solids found in water.



Planned Maintenance Kits
Includes all necessary pre-filter elements, screens, cleaning compound kits, pump crankcase oil, replacement seals for the pre-filter, and storage compound kit. Please specify system model number upon ordering.



Fresh Water Flush
Prevents fouling of the membranes and pre-filters by automatically rinsing the system with fresh water every seven days.



Water Guard 2 GRPM
Assembly filters and sterilizes dock and purchased water



Plankton Filter
Filters most microorganisms from the feed water, prolonging pre-filter life.



Charcoal Filter
Removes any unwanted flavors or smells from the product water, leaving a great, clean taste.

System Specifications

Seawater conditions for system specification:

(+/-15% at 820 psi / 56.5 bar, 77°F / 25°C & 35,000 ppm TDS feed water salinity)

Salt rejection (Chloride Ion):

Minimum 99.2%, average 99.4%

Product water temp:

Ambient to feed water temperature

Salinity monitoring:

Fail safe automatic computer controlled electronic monitoring.

Salinity range of feed water:

Seawater up to 50,000 ppm TDS (NaCl) (typical 35,000 ppm)

Temperature range:

Maximum - 122°F/50°C, minimum - 33°F/.5°C

Reverse osmosis membrane type:

High rejection / high flow aromatic tri-polyamid, thin film composite, spiral wound, reverse osmosis membrane element.

Chlorine tolerance:

0.1 PPM pH range: 3-11 (typical seawater pH is 8)

System pressure:

Feed water: Min: 2-6 psi/.41 bar/.42 Kg/cm²

Max: 30-35 psi/2.41 bar/2.46 Kg/cm²

Operation: Seawater nominal: 850 psi/56.5 bar/57.66 Kg/cm²

(Brackish varies w/ppm)

External installation water connections:

Pipe sizes to be supplied by the installer for connection of the Horizon Reverse Osmosis supplied components.

	Mini 170 / Mini 350	All Other SF systems	Escape Systems
Feed inlet:	3/8 1/2	3/4" FNPT	1/2" FNPT
Brine discharge:	3/8 3/8	1/2" FNPT	1/2" FNPT
Product:	1/4 1/4	3/8" MNPT	3/8" MNPT

Electrical power requirements:

(HP = Horse power; FLA = Full load amperes; LRA = Locked rotor amperes start up)



Picture courtesy of Hunter Marine

	Per 24 Hours Gallons / Liters	Per Hour Gallons / Liters
SFC/SFM 450-1	450 / 1,705	18 / 70
SFC/SFM 700-1	700 / 2,650	26 / 110
SFC/SFM 900-1	900 / 3,405	38 / 140
SFC/SFM 900-2	900 / 3,405	38 / 140
SFC/SFM 1400-2	1,400 / 5,300	58 / 220
SFC/SFM 1800-2	1,800 / 6,815	75 / 285

High Pressure Pump Motor and Booster Pump combined Amp Draw:

SFC/SFM 450-1 & 900-1 Systems

Phase	Hz	VAC	HP	FLA	LRA
Single	50/60	110/115	2.5	30	120
Single	50/60	220/230	2.5	15	60
Three	50/60	220/230	3.0	10.5	41
Three	50/60	230/460	3.0	5.5	22

SFC/SFM 700-1 & 1400-2, & 900-2 & 1800-2 Systems

Phase	Hz	VAC	HP	FLA	LRA
Single	50/60	110/115	2.5	30	120
Single	50/60	115/230	2.5	15	60
Three	50/60	220/230	3.0	10.5	41
Three	50/60	380/460	3.0	5.5	22

Dimensions:

Self Contained

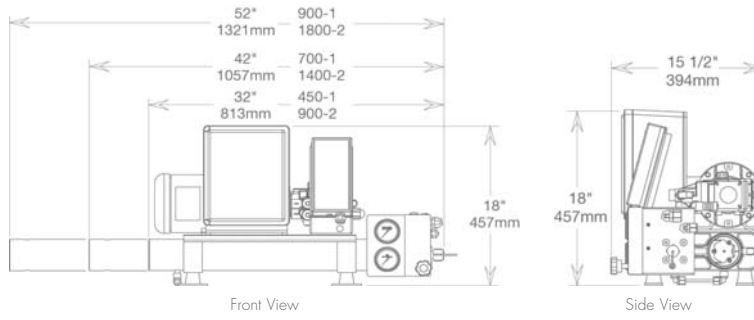

Modular

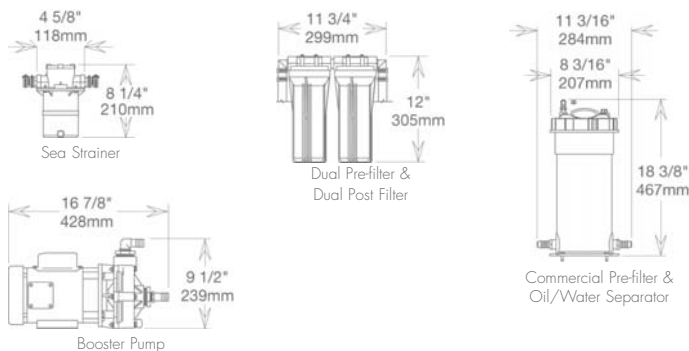
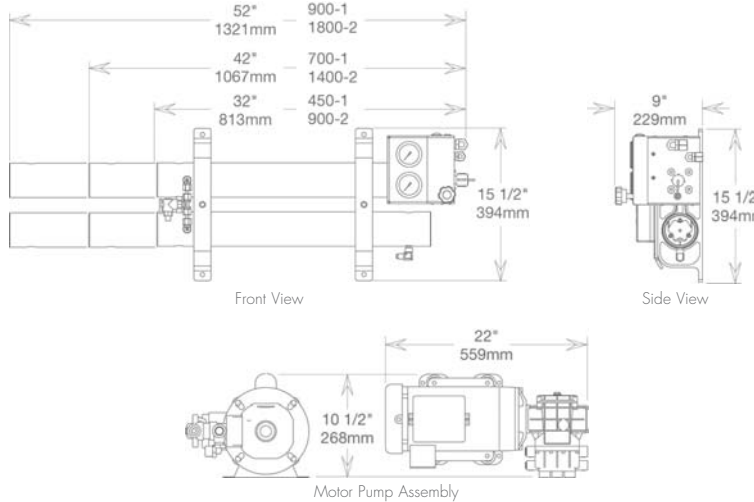

	Per 24 Hours Gallons / Liters	Per Hour Gallons / Liters
Mini 170	170 / 645	7 / 25
Mini 350	350 / 1,325	15 / 55

High Pressure Motor and Booster Pump Combined Amp Draw:

	Phase	Hz	VAC	HP	FLA	LRA
170			N/A	12V	0.333	29
			N/A	24V DC	0.333	14
Single		50/60	110	0.333	7	28
	Single	50/60	220	0.333	3.5	14
350	Single	50/60	110	1	13	52
	Single	50/60	220	1	6.5	26

Dimensions:

Mini 170

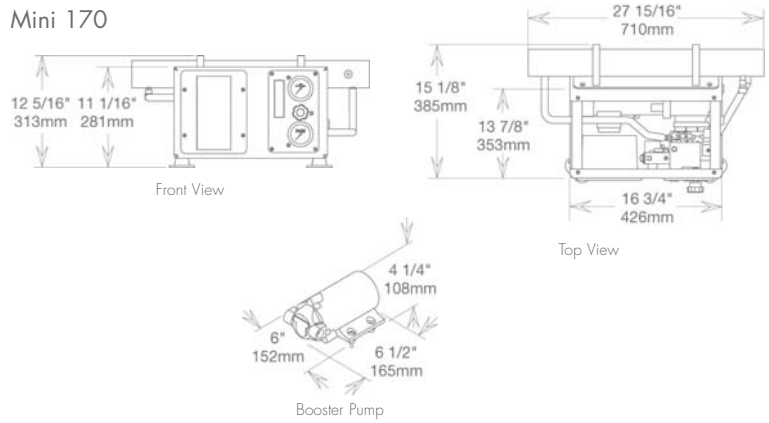

Mini 350

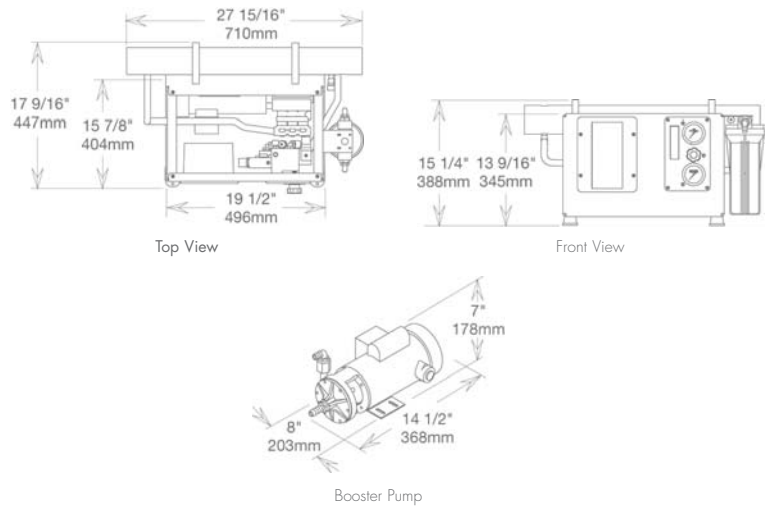

Filtration for Mini 170 & Mini 350

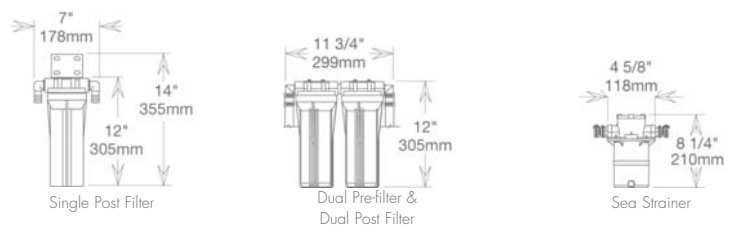

Seafari Escape™

	Per 24 Hours Gallons / Liters	Per Hour Gallons / Liters
Escape 200	200 / 760	8 / 30
Escape 300	300 / 1,135	13 / 45
Escape 400	400 / 1,515	17 / 65
Escape 500	500 / 1,895	21 / 80
Escape 600	600 / 2,270	25 / 95

High Pressure Feed Pump Motor:

Escape 200 Systems					
	Hz	VAC	HP	FLA	LRA
12V DC			.33	13.0	90
24V DC			.33	7.0	42
Phase					
Single	50/60	115	.33	6	24
Single	50/60	220	.33	3	12

Escape 300 and 400 Systems					
	Hz	VAC	HP	FLA	LRA
12V DC			.33	22.0	90
24V DC			.33	11.0	42
Phase					
Single	50/60	115	.33	6	24
Single	50/60	220	.33	3	12

Escape 500 and 600 Systems					
	Hz	VAC	HP	FLA	LRA
24V DC			.50	22.0	60
Phase					
Single	50/60	115	.50	8	32
Single	50/60	220	.50	4	16

Dimensions:

Escape Compact

1. 27 15/16" - 710mm: Compact 200
2. 37 15/16" - 964mm: Compact 300
3. 46 15/16" - 1192mm: Compact 400, 500 & 600

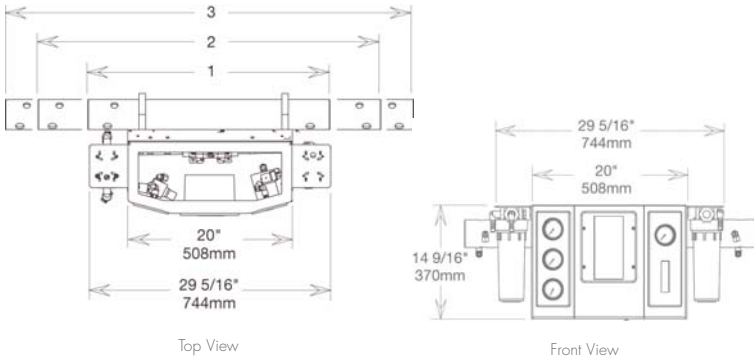

Escape Modular

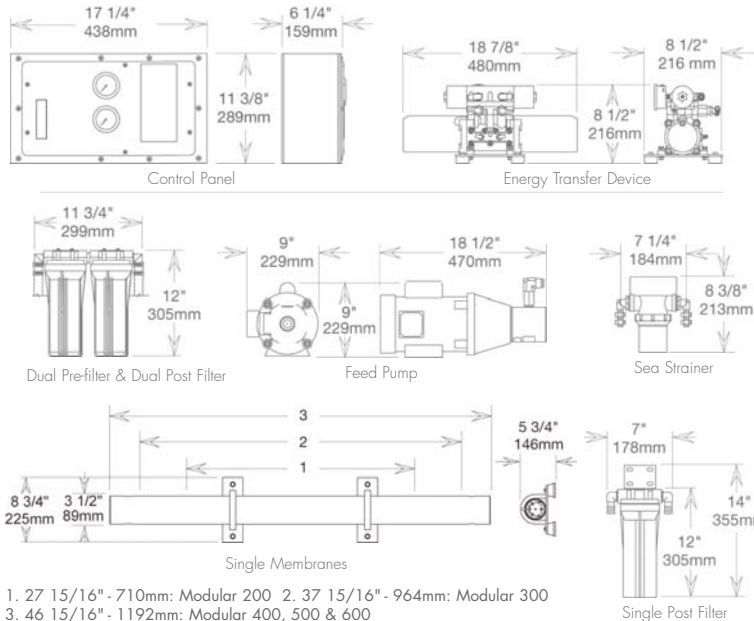

Coral Sea™

	Per 24 Hour Gallons / Liters	Per Hours Gallons / Liters
Coral Sea with 3" R.O. Membrane Elements: Horizontal, Vertical, Modular		
Coral Sea 2800	2,800 / 10,600	115 / 440
Coral Sea 3600	3,600 / 13,625	150 / 570
Coral Sea with 4" R.O. Membrane Elements: Horizontal, Vertical		
Coral Sea 4200	4,200 / 15,900	175 / 660
Coral Sea 5200	5,200 / 19,685	215 / 820
Coral Sea 6200*	6,200 / 23,470	260 / 980
Coral Sea 6800*	6,800 / 25,740	285 / 1,075

Dimensions:

Coral Sea Vertical

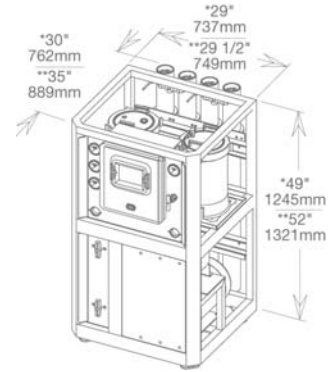

Coral Sea Horizontal

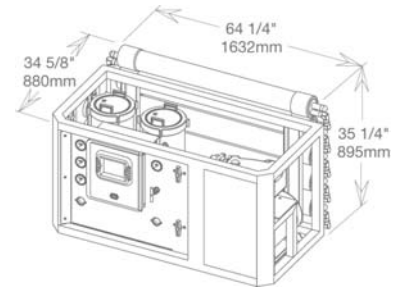

Coral Sea Modular

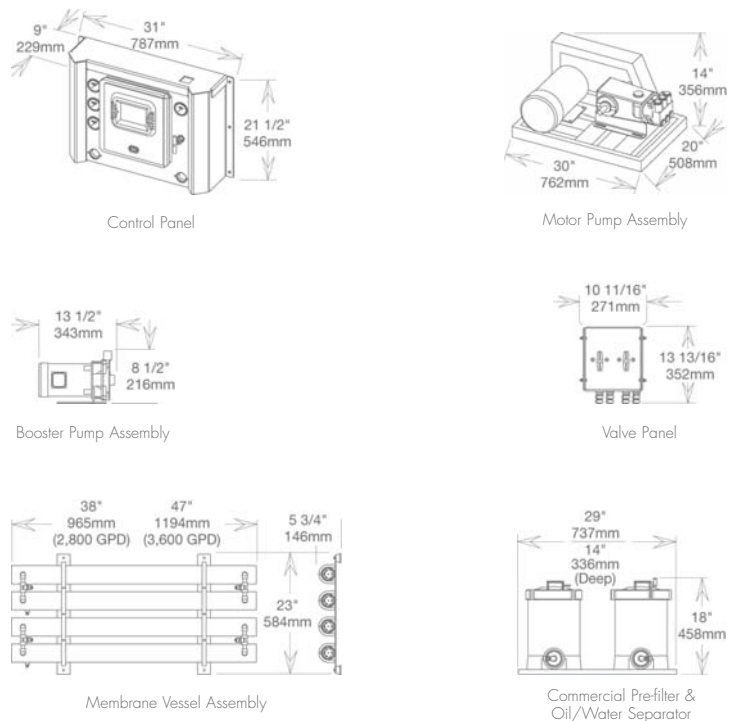

*5 and 6 piece membrane for 4" Coral Sea Horizontal 6200 & 6800 only

Authorized dealer in your area:

Front cover picture courtesy of Riviera Electronics



Horizon Reverse Osmosis
19610 South Rancho Way
Rancho Dominguez, California 90220 U.S.A.
Tel: (310) 631-6300 • Fax: (310) 631-6395
Toll Free in the U.S.A.: (800) 366-4476
Email: sales@hrosystems.com
www.hrosystems.com

REV: HROMB0908